**WARNING:**

Do not inflate this assembly when it is unrestricted. The assembly must be restricted by the suspension or other adequate structure. Do not inflate beyond 100 P.S.I. Improper use or over inflation may cause property damage or severe personal injury.

Firestone Industrial Products
Carmel, Indiana, USA

INSTALLATION INSTRUCTIONS

Congratulations - your new Ride-Rite Air Helper Springs are quality products capable of improving the handling and comfort of your vehicle. As with all products, proper installation is the key to obtaining all of the benefits your kit is capable of delivering. Please take a few minutes to read through the instructions to identify the components and learn where and how they are used. It is a good idea to start by comparing the parts in your kit with the parts list below.

The heart of the Ride-Rite kit is, of course, the air helper springs. Remember that they must flex and expand during operation, so be sure that there is enough clearance to do so without rubbing against any other part of the vehicle.

Be sure to take all applicable safety precautions during the installation of the kit. The instructions listed in this brochure and the illustrations all show the left or driver's side of the vehicle. To install the right hand assembly simply follow the same procedures.

Your kit includes separate inflation valves and air lines for each air spring. This will allow you to level your vehicle from side to side as well as from front to back. If you would rather have a single valve inflation system, your dealer can supply the required "T" fittings.

IMPORTANT!

For your safety and to prevent possible damage to your vehicle, do not exceed the maximum load recommended by the vehicle manufacturer (GVWR). Although your Ride-Rite Air Helper Springs are rated at a maximum inflation pressure of 100 p.s.i., this pressure may allow you to carry too great of a load on some vehicles. Check your vehicle owner's manual for maximum loads listed for your vehicle.

When inflating your Ride-Rite Air Helper Springs, add air pressure in small quantities, checking pressure frequently during inflation. The air spring requires much less air volume than a tire and, therefore, inflates much quicker.

PARTS LIST

AIR SPRING	6781	2	5/16"-18 BAIL CLAMP	4
UPPER BRACKET	5174	2	5/16"-18 FLANGE LOCK NUT	4
LOWER BRACKET	5129	2	5/16" FLAT WASHER	4
BRACKET STRAP	5103	4	ELBOW AIR FITTING	3101 2
18 ft. TUBING		1	INFLATION VALVE	3098 2
3/8"-16 x 3" CARRIAGE BOLT		8	NYLON TIES	6
3/8"-16 FLANGE LOCK NUT		12	THERMAL SLEEVE	
3/8"-16 x 3/4" HEX BOLT		2		

NOTE: Both illustrations are of the left, or driver's side of the vehicle.
Reverse any orientations when assembling and installing the right, or passenger's side of the vehicle.

FIGURE "A"

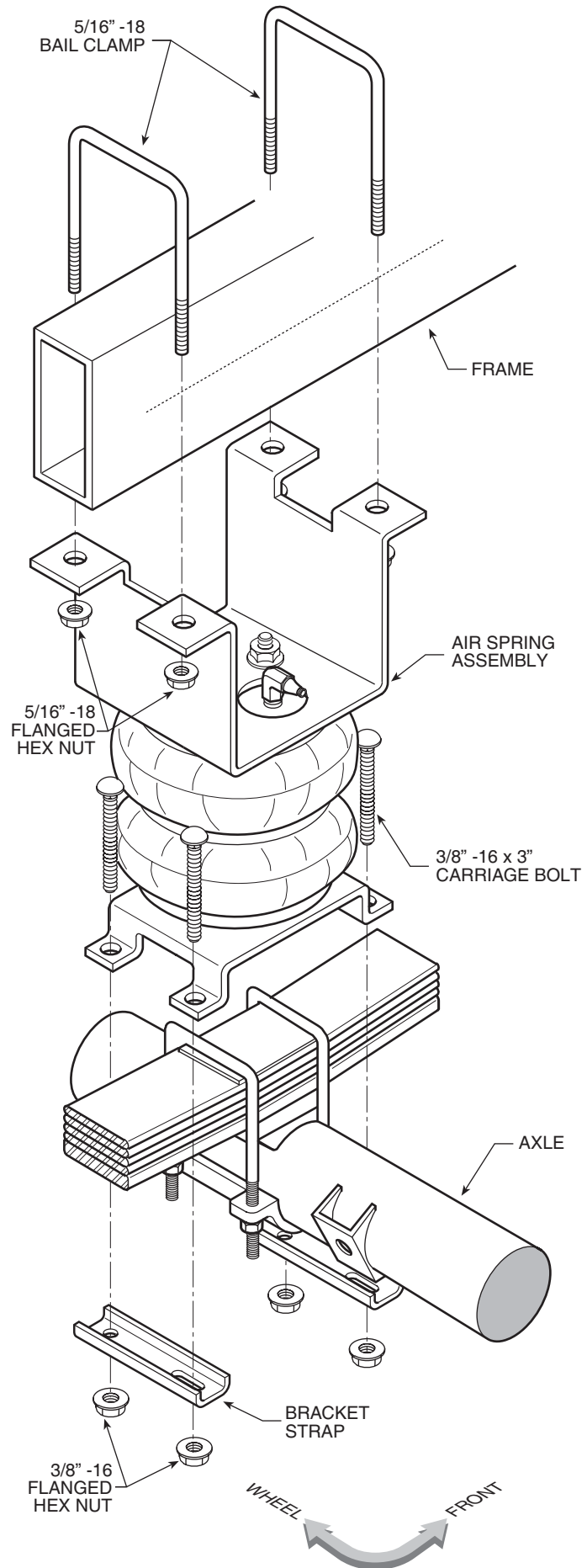
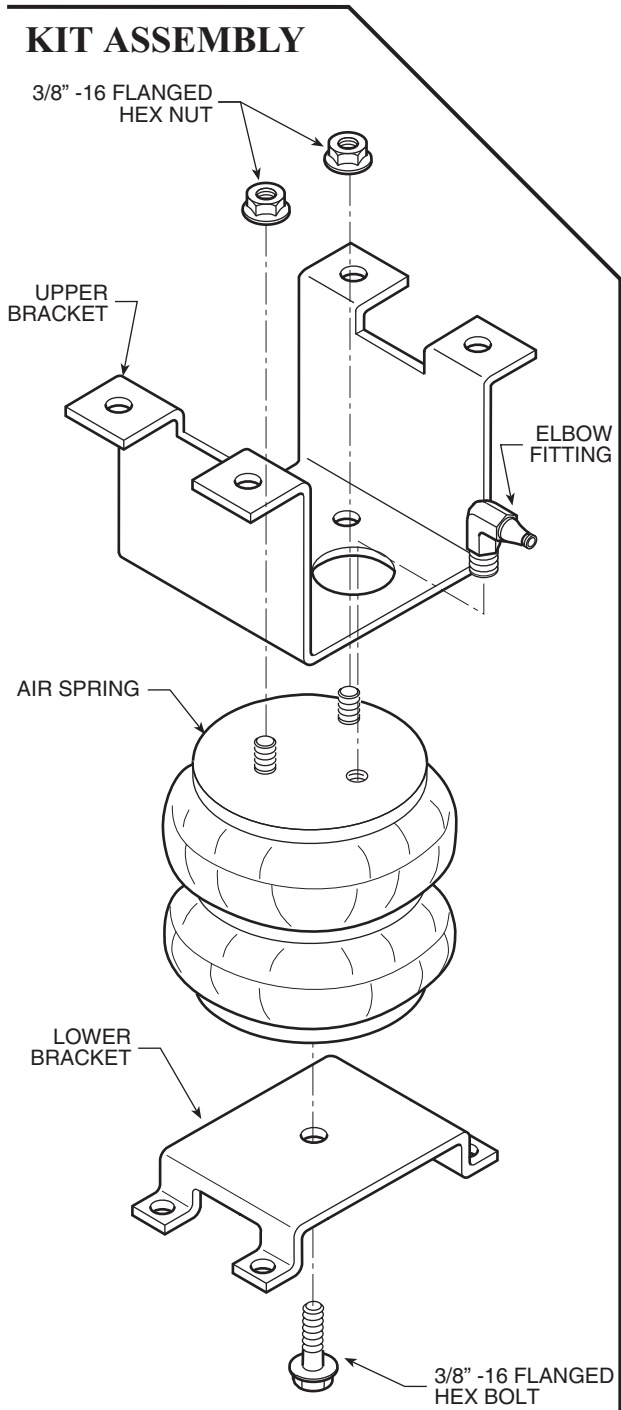

STEP 1 - PREPARE THE VEHICLE

Place the vehicle on a solid level surface. Take necessary safety precautions such as using wheel chocks when working under your vehicle. Remove the jounce bumpers by cutting them off as close to the bracket as possible as shown in Figure "B".

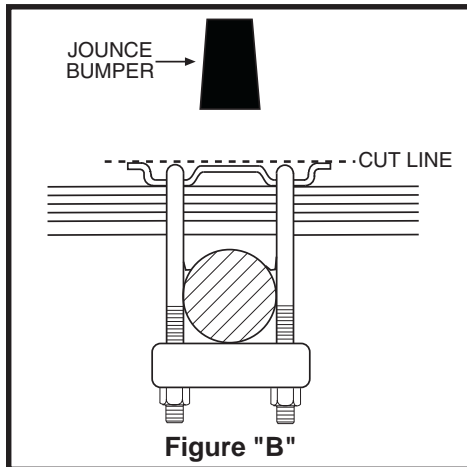

STEP 2 - PREASSEMBLE THE KIT

Select the left side upper bracket and an air spring from your kit. Install the elbow fitting into the air spring. Tighten the air fitting so as to make contact with the nylon ring and then tighten 1/2 turn to snug the fitting. No thread sealant is needed. Next attach the upper bracket to the air spring using the 3/8" -16 flange hex nuts. Tighten the hex nuts (torque to 10-15 ft. lbs.). Select the lower left bracket from your kit (see Figure "A"). Attach the lower bracket to the air spring using the 3/8"-16 x 3/4" hex bolt. Tighten the bolt making sure the bracket is in the correct position (see Figure "A") (torque to 15-20 ft. lbs.).

STEP 3 - INSTALL THE PREASSEMBLY TO THE VEHICLE

Place the preassembly on the leaf stack of the left side of the vehicle as shown in Figure "A". Attach the upper bracket directly beneath the frame rail using the 5/16" bail clamps and 5/16" lock nuts. The rear leg of the upper bracket should rest directly on the frame rail and the front leg will rest on the jounce bumper brace. Attach the lower bracket to the leaf stack using the 3" carriage bolts, 3/8" lock nuts, and bracket straps. (see Figure "A"). The bracket strap should be offset to provide adequate clearance for the emergency brake lever.

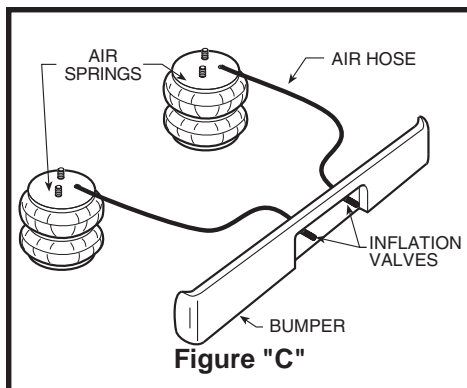

Follow the same procedures as outlined in steps 1 through 3 for installing the right side of the vehicle.

STEP 4 - INSTALL THE AIR LINE

Uncoil the air tubing and cut it into two equal lengths. DO NOT FOLD OR KINK THE TUBING. The air line tubing should not be bent or curved sharply as it may buckle with age. Make the cut as square as possible. Insert one end of the tubing into the elbow fitting installed in the top of the air helper spring.

Select a location on the vehicle for the air inflation valves. The locations can be on the bumper or the body of the vehicle, but be sure that it is in a protected location so the valve will not be damaged yet still be accessible for the air chuck (see Figure "D"). Drill a 5/16" hole or use an existing hole and install the air inflation valve using two 5/16" stainless steel flat washers per valve as supports (see Figure "E"). Run the tubing from the air spring to the inflation valve, routing it to avoid direct heat from the muffler or tailpipe, and away from sharp edges. Tubing protectors have been provided for these conditions. Push the end of the air line tubing into the inflation valve as illustrated (see Figure "E"). Secure the tubing in place with the nylon ties provided.

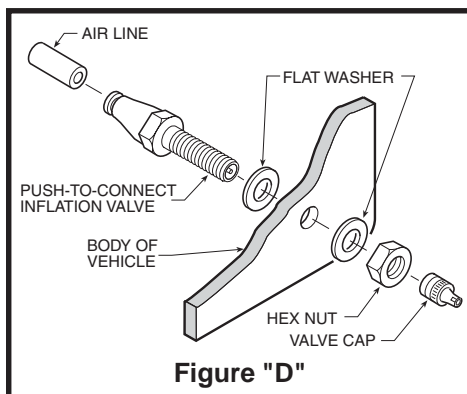

STEP 5 - CHECK THE AIR SYSTEM

Once the inflation valves are installed, inflate the air springs and check the fittings for air leaks with an applied solution of soap and water. If a leak is detected at a tubing connection then check to make sure that the tube is cut as square as possible and that it is pushed completely into the fitting. The tubing can easily be removed from the fittings by pushing the collar

towards the body of the fitting and then pulling out the tube. If a leak is detected where the fitting screws into the spring, screw the elbow into the spring until the leak stops. Reinflate the air helper springs and check for leaks as noted above. Further information on trouble-shooting can be found in the General Operation Instruction book included with this kit.

STEP 6 - INSTALLATION OF THE PASSENGER'S SIDE ASSEMBLY

Follow steps 1-5 for assembly and installation of the passenger's side assembly. Use tubing protectors to shield any overexposed air line tubing from heat or sharp edges that may damage the air line tubing. The air helper spring should be offset to the center of the vehicle. The air fitting should face the front of the vehicle on the passenger, or right, side of the truck. Care should be taken not to bend the air tubing to sharply when routing the tubing to the rear of the vehicle.

This now completes the installation. Before proceeding, check once again to be sure you have proper clearance around the bellows. With a load on your vehicle and the helper air springs inflated, you must have at least 1/2" clearance around the bellows. As a general rule, the Ride-Rite Air Helper Springs will support approximately 40 lbs. of load for each p.s.i. of inflation pressure (per pair). For example, 50 P.S. I. of inflation pressure will support a load of 2000 lbs. per pair of air helper springs. FOR BEST RIDE use only enough air pressure in the air helper springs to level the vehicle when viewed from the side (front to rear). This amount will vary depending on the load, location of load, condition of existing suspension and personal preference.

NOTE: Too much air pressure in the helper springs will result in stiffer ride, while too little air pressure will allow the air spring to bottom out over rough conditions. Too little air pressure will also not provide the improvement in handling that is possible. TO PREVENT POSSIBLE DAMAGE MAINTAIN A MINIMUM OF 3-5 P.S.I. IN THE RIDE-RITE AIR SPRINGS AT ALL TIMES.

NOTE:

Once the air helper springs are installed, it is recommended that the vehicle not be lifted by the frame, as over-extension may occur, resulting in damage to the air helper springs. However, should it become necessary to raise the vehicle by the frame, deflate both air helper springs completely.



FIRESTONE INDUSTRIAL PRODUCTS
TELEPHONE: 317-818-8600

12650 HAMILTON CROSSING BLVD.
TELEPHONE: 1-800-888-0650

CARMEL, IN. 46032
FAX: 317-818-8780