

AIR CONTROL ACCESSORY KIT

INSTALLATION INSTRUCTIONS

Congratulations on your purchase of a new Firestone Air Control Accessory Kit. This kit was designed to provide inflation control of your Firestone air helper springs. This kit will be an asset to your vehicle, meeting most all of your air supply needs.

Please take a few minutes to read through the instructions, identify the components, and learn how to properly install your Air Control Accessory Kit.

NOTE:

The Air Control Accessory kit can be used with all Firestone air helper springs products. If you are installing a Firestone suspension system do not install the air line tubing into the air springs as stated in the suspension system instruction manual. If you are adding the Air Control Accessory kit to an existing Firestone suspension system you will need to deflate the air springs and remove the air line tubing.

NOTE ON CONNECTING THE AIR LINE TUBING

Cut the air line tubing as squarely as possible. To connect the air line tubing to the fittings push the tubing into the fittings as far as possible. If for any reason the tubing must be removed the collar of the fitting can be pushed toward the body of the fitting and the tubing can be removed. Make sure the air helper springs are deflated. To reassemble make sure the tubing is cut squarely and push back into the fitting.

TOOLS REQUIRED:

- 3/16" drill bit
- 1/4" drill bit
- Electrical pliers
- Phillips screw driver
- (2) 7/16" wrenches
- 3/8" drill bit
- Hand drill
- Pliers
- Sharp knife
- Center punch

PARTS LIST

DUAL AIR CONTROL PANEL		1	3/16" WASHER	8
COMPRESSOR	9284	1	1/8" NPT STRAIGHT FITTING	1
RELAY HARNESS	9307	1	WIRE CONNECTOR	2
30 FT. AIR LINE TUBING		1	RING TERMINAL	1
15 FT. 18 GAGE WIRE		1	#10 FLAT WASHER	4
10-32" X 1" MACHINE SCREW		6	NYLON TIES	16
10-32" LOCK NUT		6		

Air Line & Wiring Diagram

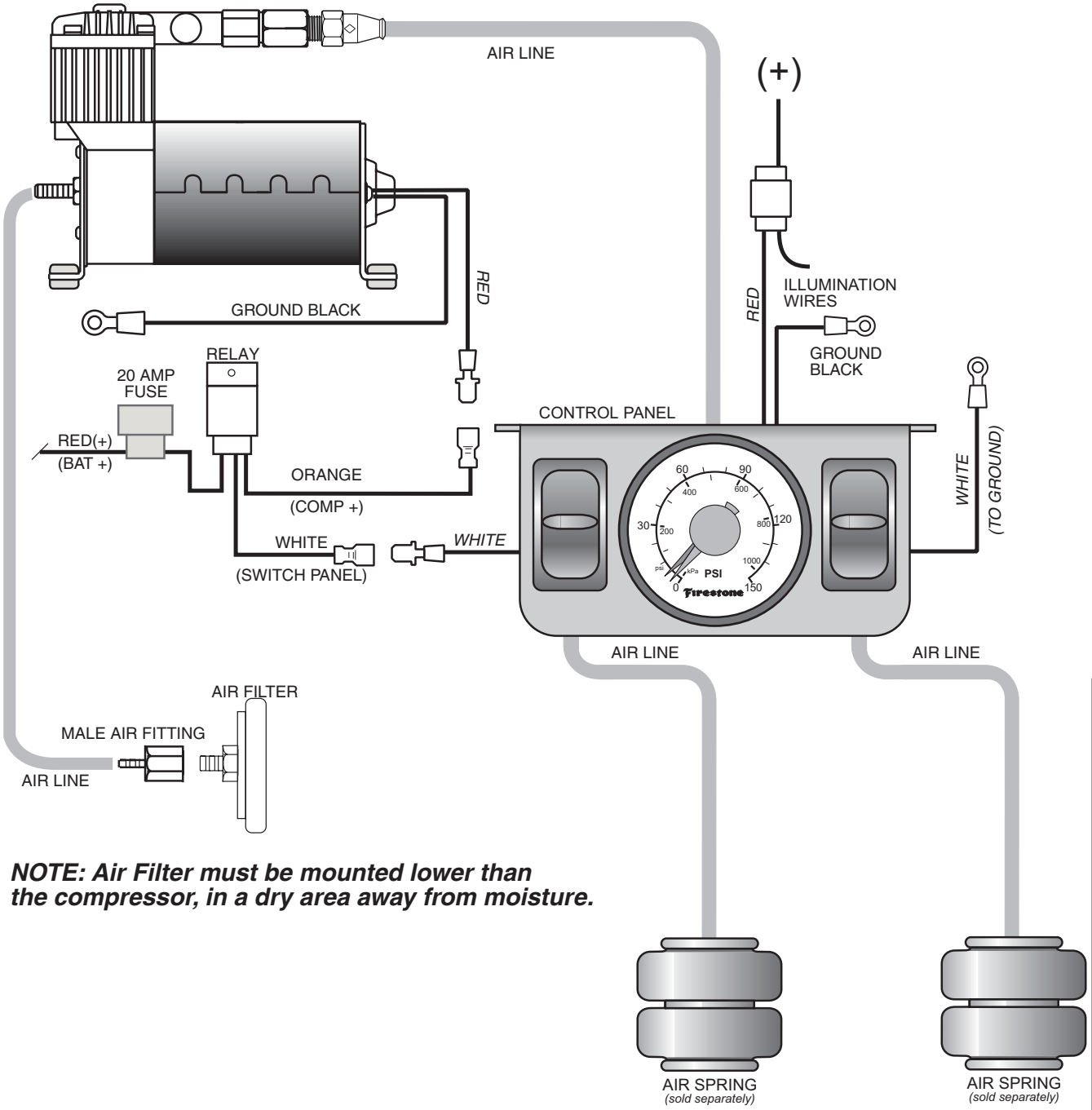

NOTE: Air Filter must be mounted lower than the compressor, in a dry area away from moisture.

Connectors:





	
Male spade connector	Femal spade connector
	
Ring Terminal	Wire connector

FIGURE "A"

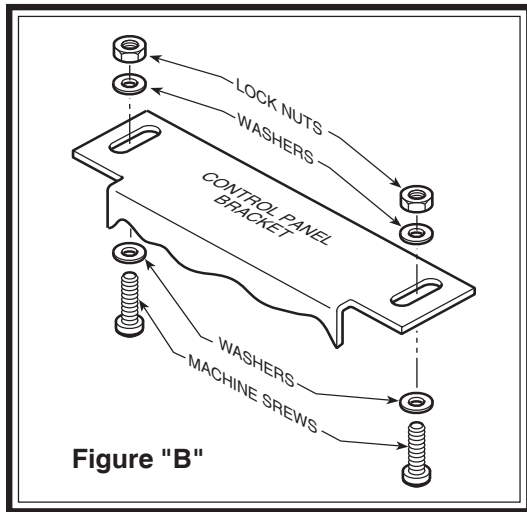

Figure "B"

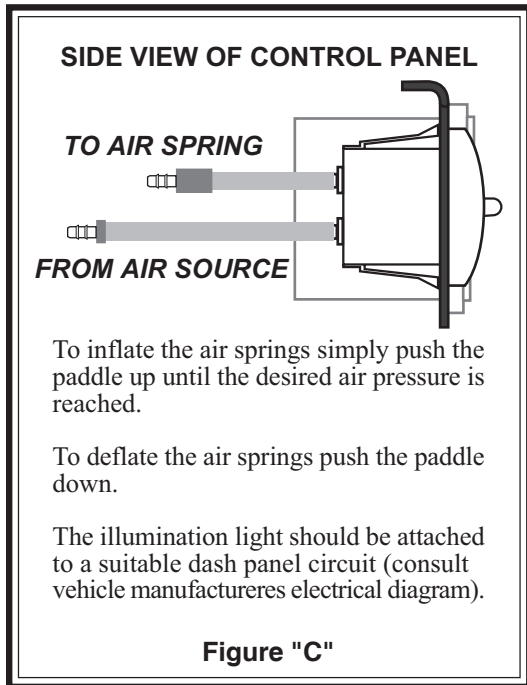

Figure "C"

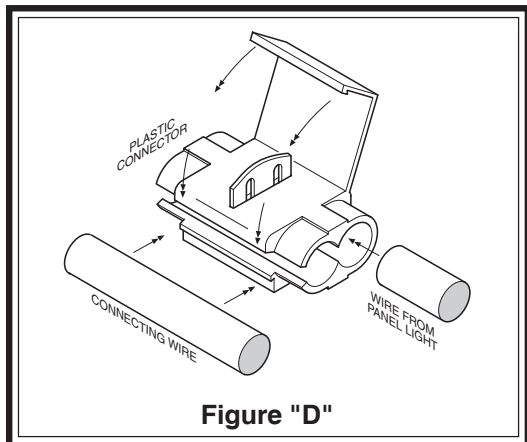

Figure "D"

STEP 1 LOCATING A MOUNTING AREA FOR THE GAUGE

Select a mounting surface under the dash of your vehicle or other protected location. Mark a 3/16" diameter hole at each of the mounting points, use the air control panel as a template for marking the holes. Drill two 3/16" diameter holes at each of the marked areas, refer to **Figure "B"**. *Do not attach the panel at this time.*

STEP 2 PREPARING THE COMPRESSOR

Take the compressor from the kit and install the 1/8" straight fitting into the head of the compressor as shown in **Figure "A"**.

STEP 3 PREPARING THE DUAL AIR CONTROL PANEL

There are two wires one red and one black attached to the gauge on the back of the air control panel for illumination. Strip the black wire 1/4" leaving the wire exposed. Crimp the ring connector to the black wire, see **Figure "A"**. (Completion of the red wire connection in step 10)

STEP 4 MOUNTING THE COMPRESSOR

Select a convenient location for mounting the air compressor. This location should provide ample air flow and be protected from airborne debris. Mark and drill four 3/16" holes using the compressor as a template for the hole location. Any burrs in the holes should be removed to prevent damage to the rubber isolators. Mount the compressor using the supplied 10-32 x 1" machine screws, 10-32 lock nuts, and 3/16" washers, see **Figure "A"**. Over tightening will crush the brass insert and the rubber isolator, reducing vibration isolation. Before drilling, ensure that there are no electrical, fuel, or brake lines on the opposite side of the mounting surface that can be damaged by the drill. Attach the ring connector on the compressor to a suitable ground source on the vehicle see **Figure "A"**.

STEP 5 CHECK FOR AIR IN THE SYSTEM

If there is no air pressure in the air springs please proceed with step 6. If there is air pressure in the air springs, both must be deflated. This is done by taking the valve core out of the external inflation valve(s) or use a tire gauge to remove the air from the air springs by depressing the valve stem.

STEP 6 ROUTING THE AIR LINE TUBING TO THE GAUGE

Cut a piece of air line tubing that will reach from the air control panel to the compressor. Before attaching the air line tubing to the air control panel soak one end (approximately 1") of the air line tubing in warm water for a few minutes. Do not use pliers to work the air line onto the barbed fitting, doing so may damage the tubing. Install and route the air line tubing from the barbed "T" fitting on the air control panel to the compressor as shown in **Figure "A"& "C"**. A hole may need to be drilled in the fire wall to enable the air line to pass through the fire wall to the compressor. Remember that 3 pieces of air line will pass through the hole in the fire wall. Make sure the air line tubing is protected from sharp edges. *Do not fold or kink the air line tubing.* The air control panel and compressor should now be connected.

STEP 7 ROUTE AIR LINE TO THE AIR SPRINGS

You will need two lengths of air line tubing, one for each air spring. Cut the two lengths of air line tubing to reach from the control panel to the air springs. Slide one section of air line previously cut onto the upper barbed fitting on the paddle switch making sure the air line tubing completely covers the barbed end of the fitting, see **Figure "C"**. Proceed with the second section of air line on the other side of the control panel.

(Hint: The left paddle switch should inflate the left air spring and the right paddle switch should control the right). Route one of the air line tubing sections from the barbed fitting on the air control panel to the rear of the vehicle being careful not to fold or kink the air line tubing. Cut the air line tubing as squarely as possible and insert the air line tubing into the push-to-connect fitting on the air spring. Repeat the above step for the other side of the air control panel. Use the nylon ties included in the kit to secure the air line to the vehicle. At this time the air control panel should be connected to both air springs.

Note: Avoid sharp edges, exhaust systems and other areas that may cause damage to the air line tubing.

STEP 8 ATTACHING THE AIR CONTROL PANEL TO THE DASH

Place the air control panel on the dash where the holes were drilled in *Step 1*. Using the machine screws and nuts provided in the kit attach the air control panel to the dash or other appropriate surface, *see Figure "B"*.

STEP 9 PREPARING AND ROUTING THE ELECTRICAL WIRE

Install the relay within three feet of the compressor. Nylon ties can be used to secure any excess wire and the relay neatly into place. Route the white wire labeled "Switch Panel" to the control panel. Connect the white wire to one of the white wires on the back of the switch. The remaining white wire will be grounded to the vehicle. Next, connect the orange wire labeled "Comp +" to the red (positive) wire on the compressor. Connect the red, fused wire labeled "Bat +" from the relay to the battery or another 12V (positive) source capable of supporting 20 amps. *See Figure "A"*.

STEP 10 WIRING THE AIR CONTROL PANEL FOR ILLUMINATION

Cut a piece of wire, it should reach a suitable fused dash panel circuit for illumination (positive). Consult the vehicle manufacturers electrical diagram. *See Figure "D"* for wiring and connector application. *NOTE:* Should additional wire be necessary, use 18 gage multistrand wire.

YOU ARE NOW READY TO TEST THE SYSTEM

With the Ride-Rite air accessory kit and Firestone suspension products installed you are ready to test the system. Turn on the ignition. Push the paddle switch up, air pressure should read on the gauge showing how much air pressure is in the air springs. Each of the air line tubing connections can be inspected with a soap and water solution applied to the fittings were the air line enters the fitting. If a leak is detected the air line may not be pushed all the way in or cut squarely.

NOTE: The air control accessory kit is designed to monitor the air pressure in the air springs not the pressure between the air compressor and the gauge. If no air is reaching the air springs, the air line tubing connections may be reversed. Please review these connections.

SYSTEM OPERATION

When the vehicle is loaded, the rear of the vehicle may drop several inches. The air control accessory kit allows the air springs to be inflated from inside the vehicle. Push the paddle up to inflate the air springs and push the paddle down to deflate the air springs.

