**WARNING!**

Do not inflate this assembly when it is unrestricted. The assembly must be restricted by the suspension or other adequate structure. Do not inflate beyond 100 P.S.I. Improper use or over inflation may cause property damage or severe personal injury.

INSTALLATION INSTRUCTIONS

Congratulations - your new Air Helper Springs are quality products capable of improving the handling and comfort of your vehicle. As with all products, proper installation is the key to obtaining all of the benefits your kit is capable of delivering. Please take a few minutes to read through the instructions to identify the components and learn where and how they are used. It is a good idea to start by comparing the parts in your kit with the parts list below.

The heart of the Air Helper Spring kit is, of course, the air helper springs. Remember that the air helper springs must flex and expand during operation, so be sure that there is enough clearance to do so without rubbing against any other part of the vehicle.

Be sure to take all applicable safety precautions during the installation of the kit. The instructions listed in this brochure and the illustrations all show the left, or driver's side of the vehicle. To install the right side assembly simply follow the same procedures.

Your kit includes separate inflation valves and air lines for each air helper spring. This will allow you to level your vehicle from side to side as well as from front to back. If you would rather have a single valve inflation system, your dealer can supply the required "T" fitting.

IMPORTANT!

For your safety and to prevent possible damage to your vehicle, do not exceed the maximum load recommended by the vehicle manufacturer (GVWR). Although your Air Helper Springs are rated at a maximum inflation pressure of 100 P.S.I., this pressure may allow you to carry too great a load on some vehicles. Check your vehicle owner's manual for maximum loads listed for your vehicle.

When inflating your Air Helper Springs, add air pressure in small quantities, checking pressure frequently during inflation. The air spring requires much less air volume than a tire and, therefore, inflates much more quickly.

PARTS LIST

AIR SPRING 25C	6959	2	5/16" FLAT WASHER	4
UPPER BRACKET	5269	2	AIR LINE TUBING, 18 FT.	1
LOWER BRACKET	5270	2	PUSH-TO-CONNECT	
5/16" -24 U-BOLT		4	ELBOW FITTING	3031 2
5/16" -24 FLANGED HEX NUT		8	PUSH-TO-CONNECT	
3/8" -16 FLANGED HEX NUT		4	INFLATION VALVE	2032 2
3/8" -16 x 3/4" FLANGED HEX BOLT		2	NYLON TIE STRAP	6
1/4" -14 x 1" SELF-TAPPING SCREW		4		

2213

KIT TO FRAME ASSEMBLY

NOTE: Both illustrations are of the left, or driver's side, of the vehicle. Reverse any orientations when installing the right, or passenger's side assembly.

FIGURE "A"

KIT ASSEMBLY

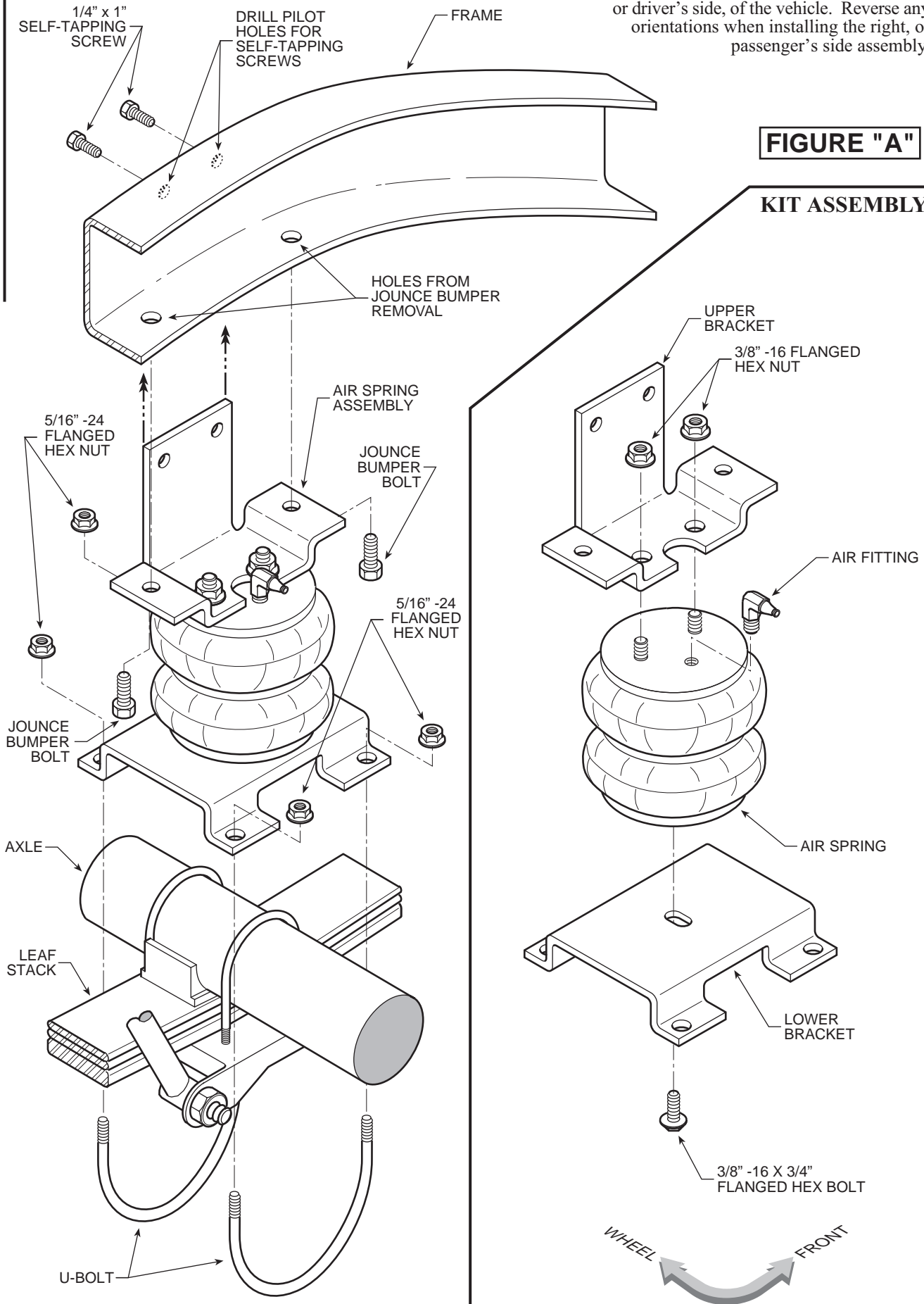

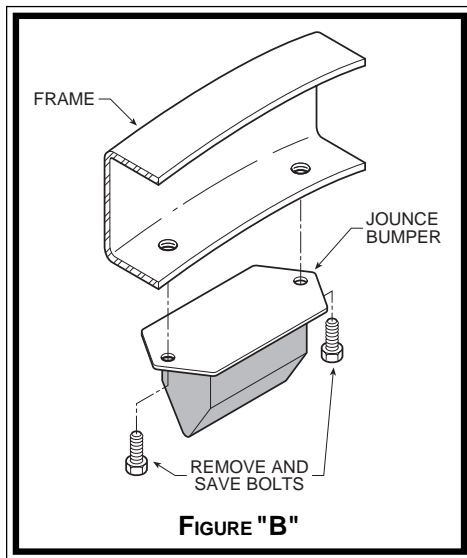

STEP 1 - PREPARE THE VEHICLE

Remove the negative battery cable. With the vehicle on a solid, level surface chock the front wheels. Raise the vehicle by the axle and remove the rear wheels. After the removal of the wheels lower the vehicle so the axle rests on jack stands rated to support your vehicles weight.

Your vehicle is equipped with rubber jounce bumpers. The bumpers are attached to the frame directly above the axle. Remove these bumpers by unbolting them from the bottom of the frame flange *see Figure "B"*. This bumper will not be reused with this kit. Do not discard the jounce bumper bolts, they will be used later in this installation.

STEP 2 - PRE-ASSEMBLE THE KIT

Pre-assembly will begin with the left (driver's) side of the vehicle. All pictures show the installation on the left side of the vehicle unless noted otherwise. Select an air spring and one upper bracket from your kit. Insert the studs on the air spring into the mounting holes in the upper bracket, making sure the air inlet hole is visible through the slot in the bracket. Secure the bracket to the air spring using two 3/8" -16 flanged lock nuts *see Figure "A"*. Next, install the air fitting through the slot in the upper bracket and into the air spring. Tighten the air fitting securely to engage the orange thread sealant. Select a lower bracket from your kit. Align the mounting slot in the lower bracket with the hole in the lower plate of the air spring. Fasten the lower bracket to the air spring using a 3/8" -16 x 3/4" flanged hex bolt (*finger tight*).

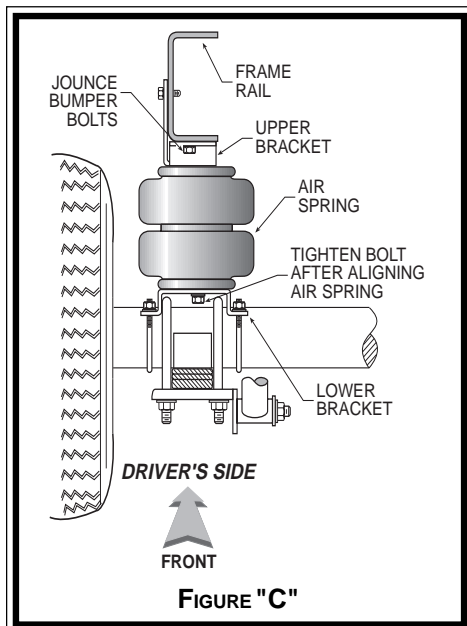

STEP 3 - INSTALL THE ASSEMBLY TO THE VEHICLE

Position the air spring assembly on top of the axle housing so that slot in the upper bracket is oriented toward the center of the vehicle while the vertical tab is flush with the outside of the frame rail. It may be necessary to compress the air spring assembly to properly position the upper bracket. Attach the horizontal tabs on the upper bracket to the bottom of the frame rail using the bolts saved from the removal of the jounce bumper *see Figure "C"*. Secure the vertical tab to the outside of the frame rail using two 1/4" -1" self-tapping screws. Drill two 1/8" pilot holes in the frame rail, using the holes in the bracket as a template *see Figure "A"*.

Vertically align the air spring and tighten the 3/8" -16 x 3/4" flanged hex bolt securing the air spring to the lower bracket *see Figure "C"*. Attach the lower bracket to the axle housing using two U-bolts and four 5/16" -24 flanged hex nuts *see Figure "A"*. The lower bracket should fit on the axle housing without interfering with the brake line. If the brake line is in contact with the lower bracket, it may be necessary to move the brake line slightly by bending it away from the contact point.

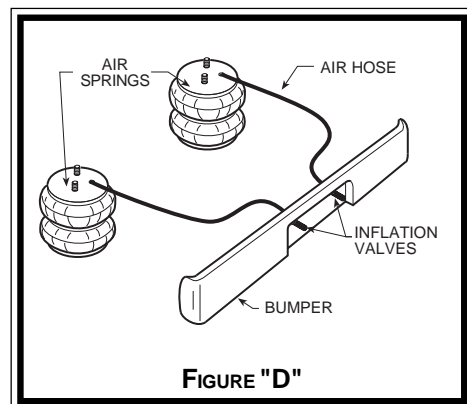

STEP 4 - INSTALL THE PASSENGER'S SIDE ASSEMBLY

Reverse any orientations when assembling and installing the air spring on the passenger's side of the vehicle.

STEP 5 - INSTALL THE AIR LINE AND INFLATION VALVE

Uncoil the air tubing and cut it in two equal lengths. **DO NOT FOLD OR KINK THE TUBING.** Make the cut as square as possible. Insert one end of the tubing into the push-to-connect elbow fitting installed in the top of the air helper spring as far as possible.

Select a location on the vehicle for the air inflation valves. The location can be on the bumper or the body of the vehicle, as long as it is in a protected location so the valve will not be damaged, but still maintain accessibility for the air chuck *see Figure "D"*. Drill a 5/16" hole and install the air inflation valve using two 5/16" flat washers per valve as supports *see Figure "E"*. Run the tubing from the air helper spring to the valve, routing it to avoid direct heat from the engine, exhaust pipe, and away from sharp edges. Thermal sleeves have been provided for these conditions. The air line tubing should not be bent or curved sharply as it may buckle. Secure the tubing in place with the nylon ties provided. Push the end of the air line tubing into the inflation valve *see Figure "E"*.

STEP 6 - CHECK THE AIR SYSTEM

Once the inflation valves are installed, inflate the air helper springs to 70 P.S.I. and check the fittings for air leaks with an applied solution of soap and water. If a leak is detected at a tubing connection, check to make sure that the tube is cut as squarely as possible and that it is pushed completely into the fitting. The tubing can easily be removed from the fittings. First, release the air pressure from the air springs. Push the collar towards the body of the fitting and then pull out the tube. If a leak is detected where the brass elbow fitting screws into the air spring, remove the tubing, then screw the elbow into the spring one additional turn or until the leak stops. Reinstall the tubing and reinflate the air springs and check for leaks as noted above.

This now completes the installation. Install the wheels and torque to the lug nuts to the manufacturer's specification. Raise the vehicle by the axle and remove the jack stands. Lower the vehicle to the ground. Reattach the negative battery cable and remove the wheel chocks from the front wheels. Before proceeding, check once again to be sure you have proper clearance around the air springs. With a load on your vehicle and the air helper springs inflated, you must have at least 1/2" clearance around the air springs. As a general rule, the air helper springs will support approximately 40 lbs. of load for each psi of inflation pressure (per pair). For example, 50 psi of inflation pressure will support a load of 2000 lbs. per pair of air helper springs. *FOR BEST RIDE* use only enough air pressure in the air helper springs to level the vehicle when viewed from the side (front to rear). This amount will vary depending on the load, location of load, condition of existing suspension and personal preference.

NOTE:

Too much air pressure in the air helper springs will result in a firmer ride, while too little air pressure will allow the air helper spring to bottom out over rough conditions. Too little air pressure will also not provide the possible improvement in handling. ***TO PREVENT POSSIBLE DAMAGE, MAINTAIN A MINIMUM OF 5 P.S.I. IN THE AIR HELPER SPRINGS AT ALL TIMES.***

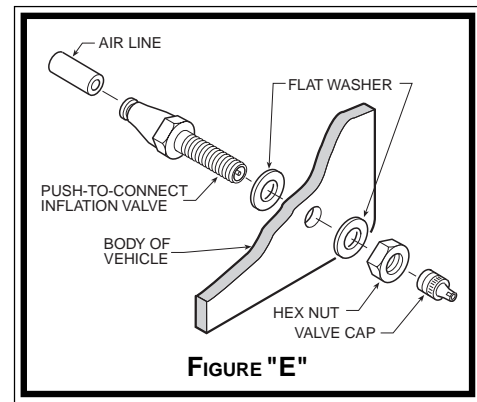

NOTE:

Once the air helper springs are installed, it is recommended that the vehicle not be lifted by the frame, as over-extension may occur, resulting in damage to the air helper springs. However, should it become necessary to raise the vehicle by the frame, deflate both air helper springs completely.