

## TOYOTA TACOMA 4X4 AND PRERUNNER

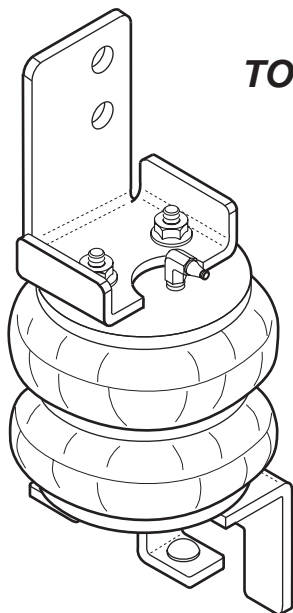

### INSTALLATION INSTRUCTIONS

Congratulations - your new Air Helper Springs are quality products capable of improving the handling and comfort of your vehicle. As with all products, proper installation is the key to obtaining all of the benefits your kit is capable of delivering. Please take a few minutes to read through the instructions to identify the components and learn where and how they are used. It is a good idea to start by comparing the parts in your kit with the parts list below.

The heart of the air spring kit is, of course, the air helper springs. Remember that the air helper springs must flex and expand during operation, so be sure that there is enough clearance to do so without rubbing against any other part of the vehicle.

Be sure to take all applicable safety precautions during the installation of the kit. The instructions listed in this brochure and the illustrations all show the left, or driver's side of the vehicle. To install the right side assembly simply follow the same procedures.

### WARNING:

Do not inflate this assembly when it is unrestricted. The assembly must be restricted by the suspension or other adequate structure. Do not inflate beyond 100 psi. Improper use or over inflation may cause property damage or severe personal injury.

This kit includes inflation valves and air lines for each air spring. This will allow you to compensate for unbalanced loads. If you would rather have a single inflation valve system to provide equal pressure to both air springs, your dealer can supply the optional "T" fitting.

### IMPORTANT!

*For your safety and to prevent possible damage to your vehicle, do not exceed the maximum load recommended by the vehicle manufacturer (GVWR). Although your Air Helper Springs are rated at a maximum inflation pressure of 100 psi, this pressure may allow you to carry too great a load on some vehicles. It is best to have your vehicle weighed once it is completely loaded and compare that weight to the maximum allowed. Check your vehicle owner's manual or data plate on driver side door for maximum loads listed for your vehicle.*

*When inflating your Air Helper Springs, add air pressure in small quantities, checking pressure frequently during inflation. The air spring requires much less air volume than a tire and, therefore, inflates much quicker.*

### TOOLS REQUIRED

- 13 MM END WRENCH
- 15 MM END WRENCH
- (2) 9/16" END WRENCHES
- (2) 1/2" END WRENCHES
- UTILITY KNIFE OR RAZOR BLADE
- HACK SAW
- 1/8" DRILL BIT
- 5/16" DRILL BIT
- ELECTRIC DRILL

### PARTS LIST

AIR SPRING	6781	2	3/8"-16 NUT PLATES	4
UPPER BRACKET	5363	2	3/8"-16 X 1" HEX HEAD BOLT	4
LOWER BRACKET	5364	2	3/8"-16 FLANGE NUT	8
FLATBRACKET STRAP	5028	2	3/8"-16 X 3/4" FLANGE LOCK	2
BRACKETSTRAP	5086	2	3/8"-16 X 1" HEX BOLT	4
18 ft. TUBING	0938	1	3/8"-16 X 3-1/2" CARRIAGE BOLT	4
PUSH-TO-CONNECT INFLATION VALVE	3032	2	5/16" FLAT WASHER	4
PUSH-TO-CONNECT ELBOW	3031	2	NYLON TIE WRAP	7
HEAT SHIELD	1004	1	CAUTION TAG	2
			THERMAL SLEEVE	2

**FIGURE "A"**

**NOTE:** Both illustrations are of the left, or drivers side, of the truck. Refer to step 3 for the proper lower bracket alignment.

**KIT ASSEMBLY**

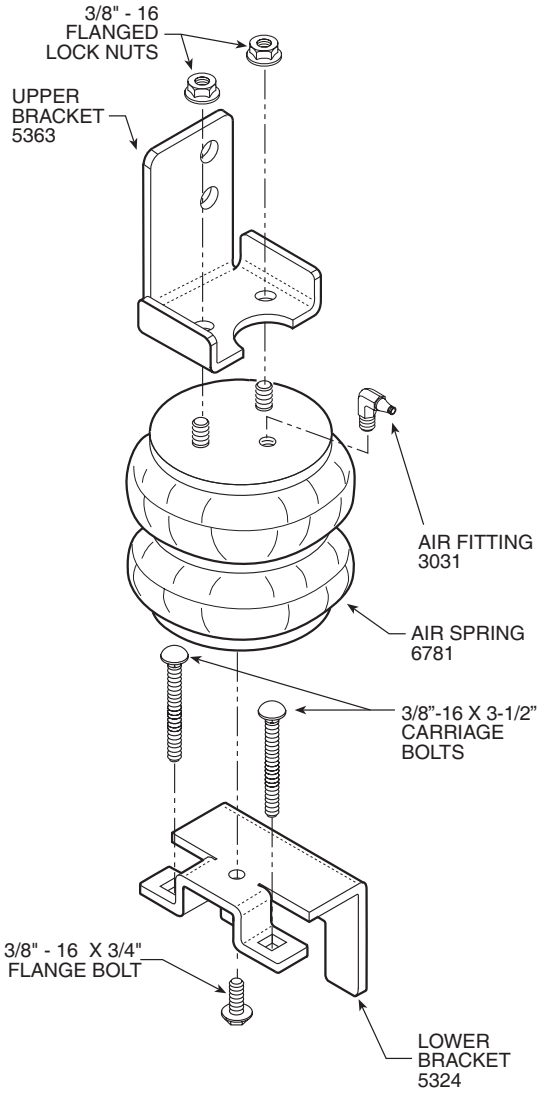

**KIT TO FRAME ASSEMBLY**

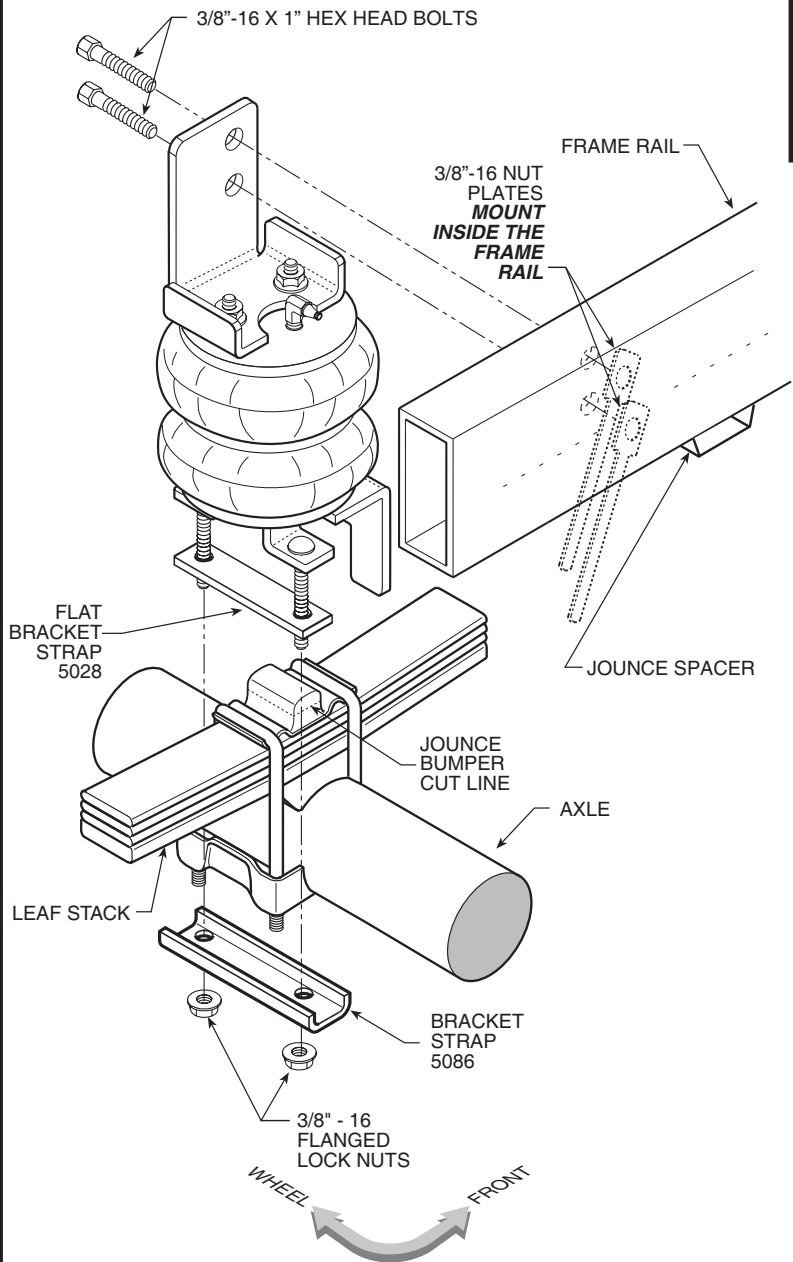

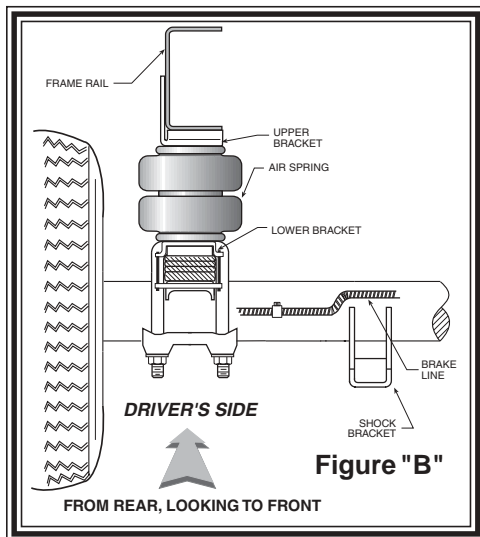

Figure "B"

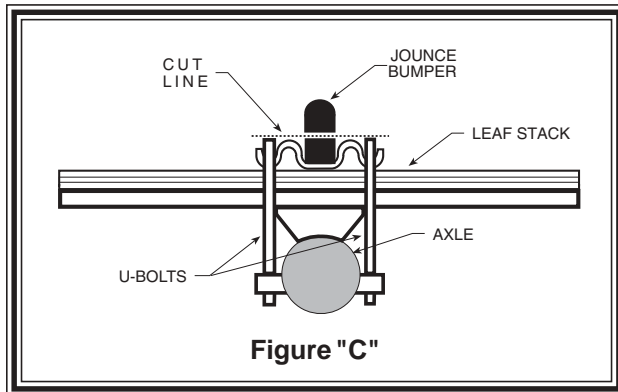

Figure "C"

of the bottom bracket is over the top of the axle U-bolt, *refer to Figure "A"*. Position the upper bracket so that the bellows are no closer than 1/2" from any part of the truck, *refer to Figure "B"*. Once the position of the upper bracket is located, mark the frame where the two holes will be drilled. Remove the assembly before drilling. **Before drilling the holes make sure all electrical, brake and fuel lines are cleared from the path of the drill.** Damage to lines can be avoided by inserting a piece of wood between the frame rail and any lines in the path of the drill. Drill the two 3/8" holes in the frame rail where marked. Next bolt the bracket strap beneath the leaf stack using the 3/8"-16 flanged lock nuts. Attach the upper bracket to the frame rail and using the provided 3/8"-16 x 1" hex head bolts and the 3/8"-16 nut plates.

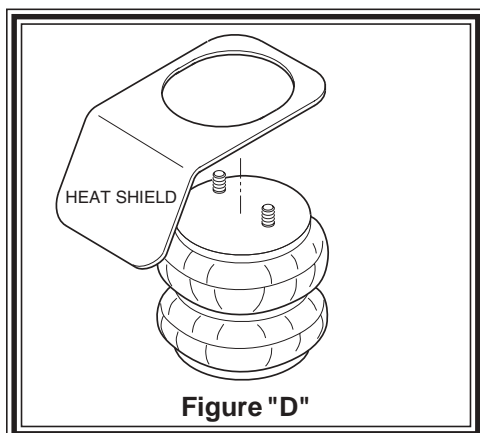

Figure "D"

spring. Push the airline tubing into the fitting as far as possible. Select a location on the vehicle for the air inflation valves. The location can be on the bumper or the body of the vehicle, as long as it is in a protected location so the valve will not be damaged, but maintain accessibility for the air chuck *see Figure "E" on the next page*. Drill a 5/16" hole and install the air inflation valve using two 5/16" flat washers per valve as supports *see Figure "F" on the next page*. Run the airline tubing from the air helper spring to the valve, routing it to avoid direct heat from the engine, exhaust pipe, and away from sharp edges. Thermal sleeves have been provided for these conditions. The airline tubing should not be bent or curved sharply as it may buckle. Secure the airline tubing in place with the nylon ties provided. Push the end of the airline tubing into the inflation valve as illustrated *see Figure "E"*.

#### NOTE:

Please read through this manual completely before installing the air spring kit to your vehicle. A heat shield is required on the exhaust side of the vehicle as noted in Step 4.

#### STEP 1 - PREPARE THE VEHICLE

With the vehicle on a solid, level surface chock the front wheels. Remove the negative battery cable. Raise the vehicle by the axle and remove the rear wheels. After the removal of the wheels lower the vehicle so the axle rests on jack stands rated for your vehicles weight. With a hack saw, cut the jounce bumper located under the frame rail **even with the U-bolts, refer to Figures "A" and "C"**.

#### STEP 2 - PRE-ASSEMBLE THE KIT

Select a lower bracket from the kit and place the 3/8"-16 x 3-1/2" carriage bolts into their designated holes. Select one air helper spring from your kit. Attach the lower bracket to the air spring using a 3/8"-16 x 3/4" flange hex bolt, *see Figure "A"*. Install the elbow fitting into the air spring. Tighten the air fitting securely to engage the orange thread sealant. Position the fitting to point to the anticipated location of the air inflation valves, *see Figure "A" & "E"*. Next, select an upper bracket from the kit and bolt the upper bracket to the air spring using 3/8"-16 flanged lock nuts. **Please note that a heat shield is required on the exhaust side of the vehicle, refer to Step 4.**

#### STEP 3 - INSTALLING THE ASSEMBLY TO THE VEHICLE

Slide the flat bracket strap over the carriage bolts until it rests against the lower bracket, *see Figure "A"*. Place the assembly on top of the leaf stack just behind the axle. Make sure that the front

#### STEP 4 - INSTALLATION OF THE PASSENGER'S SIDE ASSEMBLY

Follow steps 1-3 with reverse orientations for assembly and installation of the passenger's side assembly. **Note: The use of a heat shield is required on the passenger's side of the vehicle, see Figure "D"**. The heat shield will mount between the upper bracket and the air helper spring. Angle the heat shield so it will fall halfway between the air helper spring and the closest point on the exhaust. Be sure that the heat shield will not contact any other component as the suspension compresses (*i.e.* brake lines, shock absorbers, lower bracket assembly).

#### STEP 5 - INSTALL THE AIR LINE AND INFLATION VALVE

Uncoil the airline tubing and cut it into two equal lengths. **DO NOT FOLD OR KINK THE AIRLINE TUBING.** Try to make the cut as square as possible. Insert one end of the airline tubing into the air fitting installed in the top of the air helper

## STEP 6 - CHECK THE AIR SYSTEM

Once the inflation valves are installed, inflate the air helper springs to 70 psi and check the fittings for air leaks. Using a spray bottle, apply a solution of soap and water to the fittings. If a leak is detected at a airline tubing connection then check to make sure that the airline tube is cut as square as possible and that it is pushed completely into the fitting. The airline tubing can easily be removed from the fittings by exhausting all the pressure in the air springs and then pushing the collar towards the body of the fitting and then, with a gentle pull, remove the airline tubing. Reinstall the tubing and reinflate the air springs and check for leaks as noted above. If a leak is detected where the air fitting screws into the spring and tighten the air fitting into the air spring until the leak stops.

This now completes the installation. Install the wheels and torque the lug nuts to the manufacturer's specification. Raise the vehicle by the axle and remove the jack stands. Lower the vehicle to the ground. Reattach the negative battery cable and remove the wheel chocks from the front wheels. Before proceeding, check once again to be sure you have proper clearance around the air springs. With a load on your vehicle and the air helper springs inflated, you must have at least 1/2" clearance around the air springs. As a general rule, the air helper springs will support approximately 50 lbs. of load for each psi of inflation pressure (per pair). For example, 50 psi of inflation pressure will support a load of 2500 lbs. per pair of air helper springs. *FOR BEST RIDE* use only enough air pressure in the air helper springs to level the vehicle when viewed from the side (front to rear). This amount will vary depending on the load, location of load, condition of existing suspension and personal preference.

### NOTE:

Too much air pressure in the air helper springs will result in a firmer ride, while too little air pressure will allow the air helper spring to bottom out over rough conditions. Too little air pressure will not provide the improvement in handling that is possible. **TO PREVENT POSSIBLE DAMAGE MAINTAIN A MINIMUM OF 5 psi IN THE AIR HELPER SPRINGS AT ALL TIMES.**

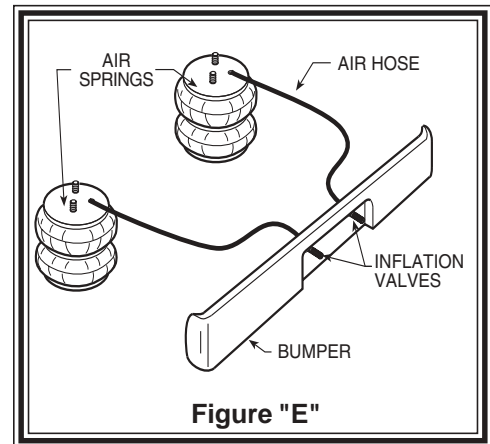

Figure "E"

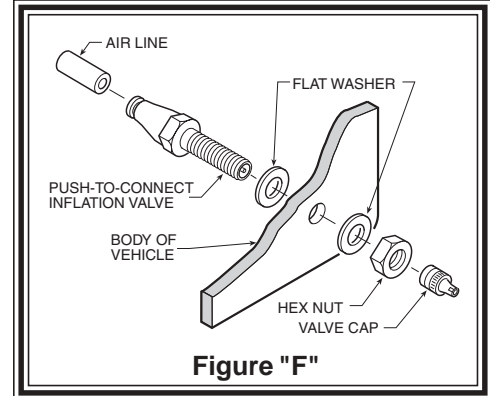

Figure "F"

### NOTE:

Once the air helper springs are installed, it is recommended that the vehicle not be lifted by the frame, as over-extension may occur, resulting in damage to the air helper springs. However, should it become necessary to raise the vehicle by the frame, deflate both air helper springs completely.

