



## INSTALLATION INSTRUCTIONS

**Read installation instructions in its entirety before installing your Coil-Rite Kit**

### NOTE 1:

If your vehicle is equipped with vibration dampers between the turns of the coil, it is necessary that these be removed before installing the air springs.

### NOTE 2:

Some mid-size General Motors vehicles have a solid surface located on the lower spring seat which will not allow the air line to exit the coil. Removal of this cup is mandatory before installing the Coil-Rite air helper springs. The cup is spot welded and can be removed by using a chisel.

### NOTE 3:

1991 and up Ford Crown Victoria, Mercury Grand Marquis, Chevy Suburban, Tahoe, GMC Yukon, Honda Passport and Isuzu Amigo, Rodeo, Trooper, and Nissan Patrol use Step 2B.

### VEHICLE PREPERATION

With the vehicle on a solid level surface chock the front wheels. Raise the vehicle using a lift or

platform jack rated for your vehicle weight to lift the rear wheels off the surface. Remove the rear wheels. Lower the vehicle onto jack stands rated for your vehicles weight making sure the suspension is fully extended. (Do NOT use wood or concrete blocks to support the weight of the vehicle.)

### HEAT SHIELD

Before beginning the installation of your Coil-Rite kit, check the clearance from the coil spring to the exhaust. If there is less than two inches you will need to move the exhaust pipe for additional clearance. Heat shield instructions are on a supplemental sheet included with your kit. (*Note: Heat shield is not used in the 4110 kit*)

### SHOCK ABSORBERS

If necessary, additional clearance between the coil spring turns may be obtained by removing the shock absorbers from the lower mounts and lowering the suspension an additional one to two inches. (CAUTION: Do not put strain or tension on the flexible brake line.)

### PARTS LIST

DESCRIPTION	QTY.
AIR SPRINGS	2
LOWER SUPPORTS	2
18' AIR LINE	1
NYLON TIE	6
PUSH-TO-CONNECT INFLATION VALVE	2
5/16" FLAT WASHER	4

### RECOMMENDED OPERATING PRESSURES

PASSENGER CARS	5-35 p.s.i.
1/2 TON VEHICLES	5-45 p.s.i.
SUV's	5-35 p.s.i.

# COIL-RITE INSTALLATION PROCEDURE

## WARNING

Do not inflate this assembly when it is unrestricted. The assembly must be restricted by a coil spring. Do not ever inflate beyond recommended operating pressures for your specific vehicle. Improper use or over inflation may cause property damage or severe personal injury.

## STEP 1 AIR SPRING PREPARATION

Cut a section of air line tubing 3 inches in length and install into the push-to-connect fitting on the air spring. Exhaust the air from the air spring by rolling it up toward the air inlet. Install the plug into the tubing coming out of the air spring.

## STEP 2A INSTALLING THE AIR SPRING

Insert the flattened air spring into the coil spring through the lowest opening with the push-to-connect air inlet at the bottom of the coil spring refer to *Figure "AA"*.

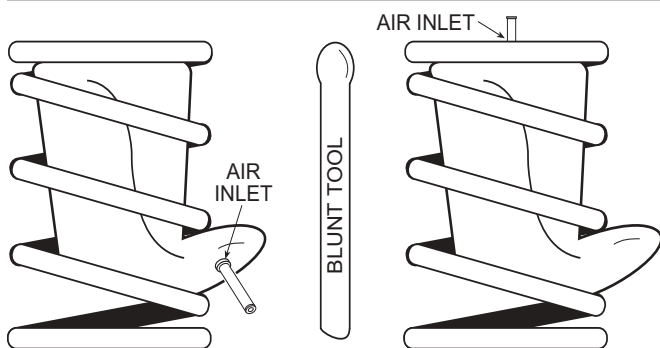


Figure "AA"

Figure "AB"

## STEP 2B INSTALLING THE AIR SPRING

Insert the flattened air spring into the coil spring through the lowest opening with the push-to-connect air inlet at the top of the coil spring as shown in *Figure "AB"*.

## STEP 3 ADJUSTING THE AIR SPRING

Push the air spring up into the coil spring by hand or with a blunt tool, such as a spoon shaped tire iron or 1/2" extension. Do **NOT** use anything with sharp edges or corners as this may damage the air spring.

## STEP 4 PLACING SUPPORTS

When the air spring is completely within the coil spring, remove the plug and short piece of air line by pushing the collar of the fitting towards the air spring. Allow the air spring to return to its normal shape. Push the air spring to the top of the coil spring. Insert the support between the air spring and the coil spring seat as shown in *Figures "BA", "BB" and "C"*.

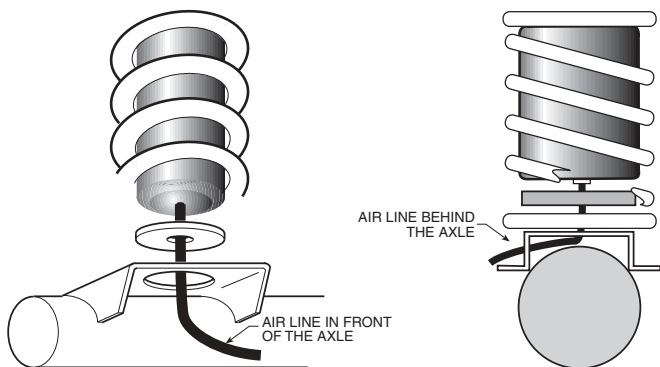


Figure "BA"

Figure "BB"

GM 1967-1972 vehicles,  
Ford 1966-1978 vehicles  
air line behind the axle.

GM 1973 & up Passenger  
Cars, Ford 1979-1990  
vehicles air line behind the  
axle.

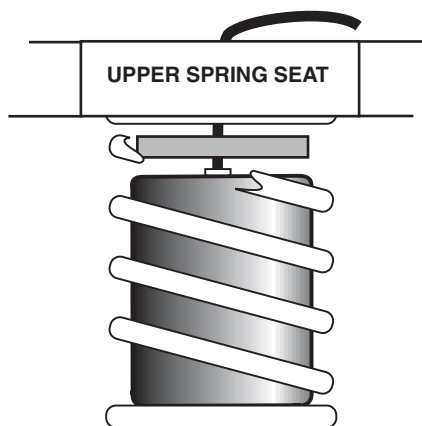
## STEP 5 REATTACH THE SHOCK ABSORBER

Attach shock absorbers if removed earlier in the installation.

*Please take all necessary safety precautions  
when installing your Coil-Rite kit.*

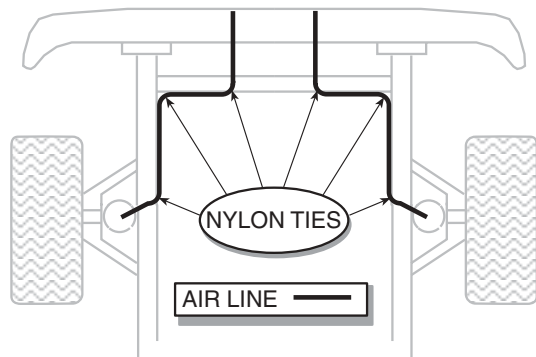
# EXTENSION HOSE INSTALLATION

**Read instructions completely before installation.**

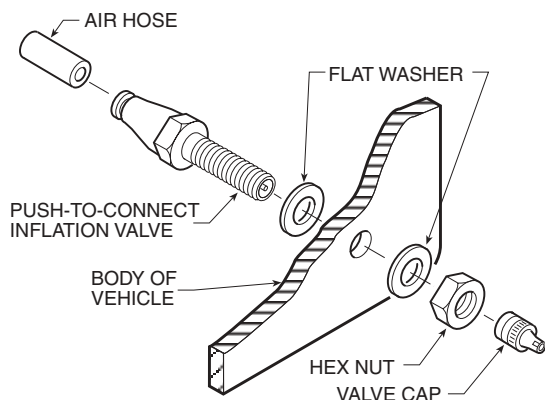


**Figure "C"**

1991 and up Ford Crown Victoria  
1991 and up Mercury Grand Marquis



**Figure "D"**



**Figure "E"**

## STEP 6 ROUTE THE AIR LINE

Cut the air line tubing into two equal lengths (cut the tubing as squarely as possible). Select a location for the inflation valves in a protected area, such as: on the bumper or body (Note: The inflation valve will be installed in step 8).

Insert the air line tubing into the push-to-connect fitting on the air spring as far as possible. Route the air line from the air spring to the desired inflation valve location.

## STEP 7 HOSE ATTACHMENT TO THE VEHICLE

With the tubing routed from the air spring to the location of the inflation valve. Use the nylon ties supplied to secure the air line tubing to the vehicle as shown in *Figure "D"*. Be careful to avoid heat and sharp edges when fastening the tubing to the vehicle. Route the tubing away from the exhaust system.

## STEP 8 INSTALLING THE INFLATION VALVE

Drill a 5/16" hole where you wish to mount the inflation valve. Remember to keep the inflation valve in a protected area that is easily accessible. Attach the inflation valve to the bumper or body of the vehicle as shown in *Figure "E"*. Tighten all nuts at this time.

Cut the excess air line tubing so that it will fit easily into the inflation valve, making sure the end is cut squarely (a "saw" cut with a sharp knife is preferred). Push the end of the tubing into the inflation valve as far as possible.

**Follow steps 1-8 for the other air spring.**

## STEP 9 INFLATE AND TEST

Inflate the air springs to recommended maximum operating pressure (see page 1 for operating pressures). With a soap and water solution, check for air leaks around the fittings and valve core. Jack up the vehicle, remove the jack stands and lower the vehicle to the ground. We recommend inflating and deflating in 5 p.s.i. increments to find the ideal riding condition for your vehicle.

**NOTE:** Check air pressure on a monthly basis.

***Limited Warranty for  
COIL-RITE Air Helper Springs and Accessories***

Firestone Industrial Products Company warrants that Coil-Rite products will be free from defects in workmanship or materials for a period of 24 months or 24,000 miles (whichever occurs first) from date of installation. This does not include installation or other service charges for replacement.

For an adjustment under this warranty, contact your dealer or call Firestone.

TO THE EXTENT PERMITTED BY LAW, WE DISCLAIM CONSEQUENTIAL DAMAGES. SOME STATES DO NOT ALLOW THE EXCLUSION OR LIMITATION OF INCIDENTAL OR CONSEQUENTIAL DAMAGES, SO THE ABOVE LIMITATION OR EXCLUSION MAY NOT APPLY TO YOU.

This warranty gives you specific legal rights and you may also have other rights which vary from state to state.

**For more information or technical  
assistance call:  
1-800-888-0650**